



# H Series

Probe Type Humidity Sensors 1% and 2% NIST, or Standard 2%, 3%, or 5%



U.S. Patent No. 5,922,939

**5 Year**  
Warranty

76

H Series duct mount humidity transmitters provide outstanding installation savings, exceptional accuracy, long-term stability and are best in the industry for serviceability. The electronics are sealed inside the duct probe, thereby preventing failures resulting from condensation. The thin-film capacitive HS sensor elements are factory calibrated using NIST traceable calibration equipment, are field replaceable and never require field calibration. Field replacement of the sensor element is a snap with the patented removable sensor.

### Sense humidity in harsh environments

- Thin-film polymer capacitive sensor element recovers from 100% saturation
- Electronics are encapsulated in stainless probe to resist corrosion
- Fully interchangeable element to 1%, 2%, 3% or 5% accuracy. Calibration-free!



### Applications

- Energy management systems
- HVAC control for improved comfort & energy savings
- Museums, schools, printing shops and other locations requiring humidity control
- Facilitate compliance with ASHRAE standards for environmental control and indoor air quality

### Rugged industrial design

- Pendant, duct and insertion versions for application flexibility
- Duct sensor element can be serviced without disturbing conduit
- Polarity insensitive, two-wire 4-20mA, or 3-wire, 0-5V/0-10VDC versions... flexible systems compatibility

### Calibration-free interchangeable NIST traceable HS element

- Replace digital sensor quickly without calibration... maintain accuracy and eliminate downtime
- HS element is microprocessor profiled with on-board nonvolatile memory
- Multi-point digital calibration to NIST standards
- NIST certification available
- Recovers from 100% saturation...no damage to sensor

### ORDERING INFORMATION

| (Enclosure)                | (Accuracy)               | (NIST)                   | (Output)                 | (US or EU)               | (Temp.)                  |
|----------------------------|--------------------------|--------------------------|--------------------------|--------------------------|--------------------------|
| H <input type="checkbox"/> | <input type="checkbox"/> | <input type="checkbox"/> | <input type="checkbox"/> | <input type="checkbox"/> | <input type="checkbox"/> |
| D = RH Duct                | 1 = 1%                   | N = NIST                 | M = 4-20mA               | S = Standard             | T = Temp                 |
| N = RH Insertion           | 2 = 2%                   | X = None                 | V = 0-5V/0-10VDC         | C = CE                   | X = No Temp (Stop here)  |
| P = RH Pendant             | 3 = 3%                   |                          |                          |                          |                          |
|                            | 5 = 5%                   |                          |                          |                          |                          |

### Humidity Transmitter Combination

| (Sensor Type)            | (Range)                        | OPTION (Temp Cert)       |
|--------------------------|--------------------------------|--------------------------|
| <input type="checkbox"/> | <input type="checkbox"/>       | <input type="checkbox"/> |
| A = Transmitter          | 1 = -58° - 122°F (-50° - 50°C) | (blank = None)           |
|                          | 2 = 32° - 122°F (0° - 50°C)    | 1 = 1pt Cal              |
|                          |                                | 2 = 2pt Cal              |

### Humidity RTD/Thermistor Combination

| (Sensor Type)                        | OPTION (Temp Cert)       |
|--------------------------------------|--------------------------|
| <input type="checkbox"/>             | <input type="checkbox"/> |
| B = 100R Platinum, RTD               | (blank = None)           |
| C = 1k Platinum, RTD                 | 1 = 1pt Cal              |
| D = 10k T2, Thermistor               | 2 = 2pt Cal              |
| E = 2.2k, Thermistor                 |                          |
| F = 3k, Thermistor                   |                          |
| G = 10k CPC, Thermistor              |                          |
| H = 10k T3, Thermistor               |                          |
| J = 10k Dale, Thermistor             |                          |
| K = 10k w/11k with Shunt, Thermistor |                          |
| M = 20k NTC, Thermistor              |                          |
| N = 1800 ohm TAC, Thermistor         |                          |
| Q = 1uA/°C, Linitemp                 |                          |
| R = 10k US, Thermistor               |                          |
| S = 10k 3A 221, Thermistor           |                          |
| T = 100k, Thermistor                 |                          |

**Example: (No Temp)**

H  P  2  X  V  S  X

**Example: (With Temp)**

H  D  2  X  V  S  T  C  2



### ACCESSORIES

Water guard and other accessories, see page 234



**WIRING DIAGRAMS**

*HD Series (4-20 mA Versions)*

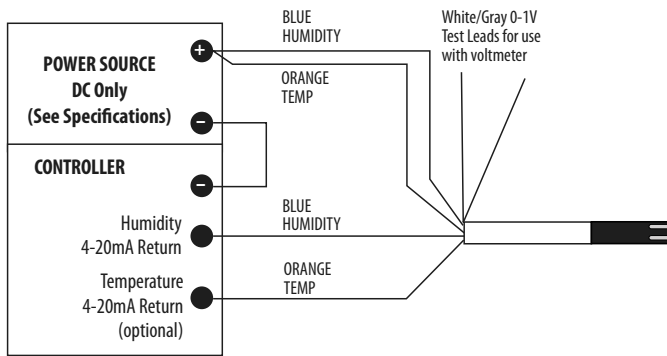

*HD Series (0-5V/0-10V Versions)*

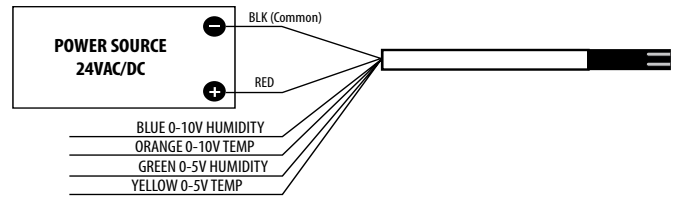

**DIMENSIONAL DRAWINGS**

*HD Series*

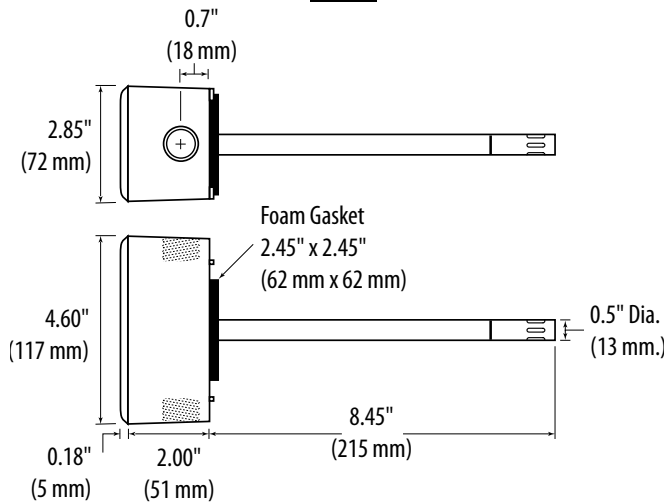

*HN Series*

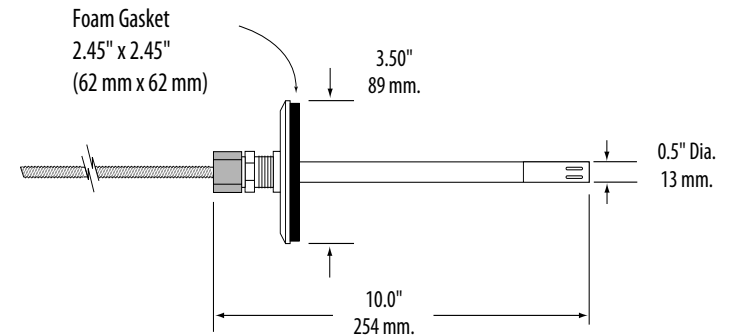

*HP Series*

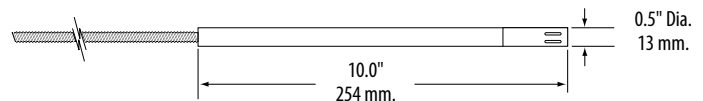

**SPECIFICATIONS**

|   |   |
|---|---|
| HS Element                              | Digitally profiled thin-film capacitive (32 bit mathematics) U.S. Patent 5,844,138                                  |
| Accuracy                                | ±1%, 2%, 3%, or 5% (specify) @ 10 to 90% RH; Four-point calibration, Multi-point certification, NIST traceable      |
| Reset Rate*                             | 24 hours  |
| Stability                               | ±1% @ 20°C (68°F) annually, for two years   |
| Operating Humidity Range                | 0 to 100% RH  |
| Temperature Coefficient                 | +0.15% RH/°C below 25°C; -0.15% RH/°C above 25°C (typical)  |
| Analog Output                           | 4-20mA version; 2-wire, polarity insensitive, (clipped and capped)<br>0-5V/0-10V versions; 3-wire, observe polarity |
| Scaling                                 | 0-100% RH   |
| Input Power                             | 4-20mA version; loop powered 12-30VDC only, 30mA max.<br>0-5V/0-10V versions; 12-30VDC/24VAC, 15mA max.             |
| Optional Temperature Transmitter Output | Digital, 4-20mA, (clipped and capped) or 0-5V/0-10V output; accuracy ±0.5°C (±1°F)                                  |
| EMC Conformance – CE Option             | EN 50081-1, EN 50082-1, EN 61000-4-4, EN 61000-4-5, EN 61000-4-3, ENV 50204, EN 61000-4-6                           |

\*Reset Rate is the time required to recover to 50% RH after exposure to 90% RH for 24 hours.

One side of transformer secondary is connected to signal common, so an Isolation transformer or dedicated power supply may be required.

Shielded cabling is required for conformance to EMC standards. Technical information is available from factory upon request or is available on our website: [www.veris.com](http://www.veris.com)