



H808



Hawkeye® 808 Series

Mini Solid-Core Adjustable Setpoint Digital Output Current Switches

The **Hawkeye 808 Series** is a high performance miniature solid-core current status switch. Its low minimum setpoint (0.75A) and small size make it ideal for monitoring status of small to medium motor loads. With an amperage range of 0.75 to 50 amps, the 808 series can accurately detect belt loss, coupling shear, or other mechanical failure on loads from 1/5 to 40HP.

APPLICATIONS

- Detect belt loss, coupling shear and mechanical failure
- Verify lighting circuit and other electrical service run times
- Monitor status of industrial process equipment
- Monitor status of critical motors (compressor, fuel, etc.)

High performance miniature solid-core

- Low (0.75A) minimum setpoint...eliminates the need for multiple wraps of the conductor through the sensor even on loads as small as 1/5HP
- Small size fits easily inside small starter enclosures
- Adjustable/Removable mounting bracket optimizes in field versatility
- Status LEDs for easy setup and local indication
- 1 Amp status output for increased application flexibility

Monitor status of fans, pumps & electrical loads

- Detects belt loss and mechanical failure...ideal for fan/pump status monitoring
- Reliable cost-effective fan/pump status sensor...the 808 series replaces pressure switches and other electromechanical devices...no fitting or tapping required
- Adjustable set point (0.75-50A)
- 100% solid state...no moving parts to fail
- 5-year limited warranty

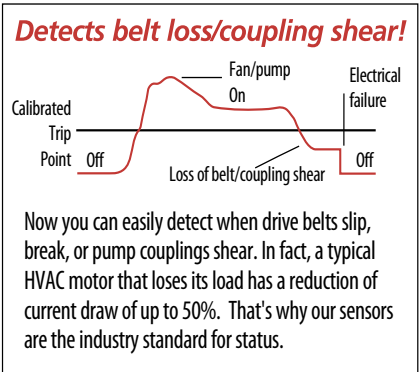

ORDERING INFORMATION

MODEL	AMPERAGE RANGE	OUTPUT TYPE (Max.)	TRIP POINT ADJUSTMENT	STATUS OPEN LED	STATUS CLOSED LED
H808	0.75 - 50A	N.O. 1.0A@30VAC/DC	●	●	●
H806*	0.75 - 50A	N.C. 0.1A@30VDC	●	●	●
H809**	0.75 - 50A	N.O. 0.2A@120VAC/DC	●	●	●

*Hx06 Models require a constant source of 5-30VDC power to the status contacts.

**CE not currently available on this product



ACCESSORIES

DIN Rail Clip Set...See page 234

APPLICATIONS/WIRING EXAMPLE

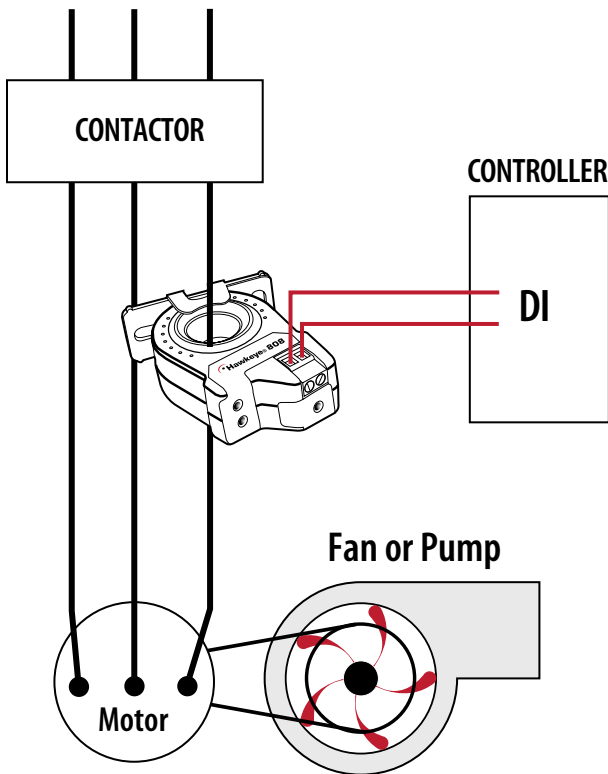

DIMENSIONAL DRAWINGS

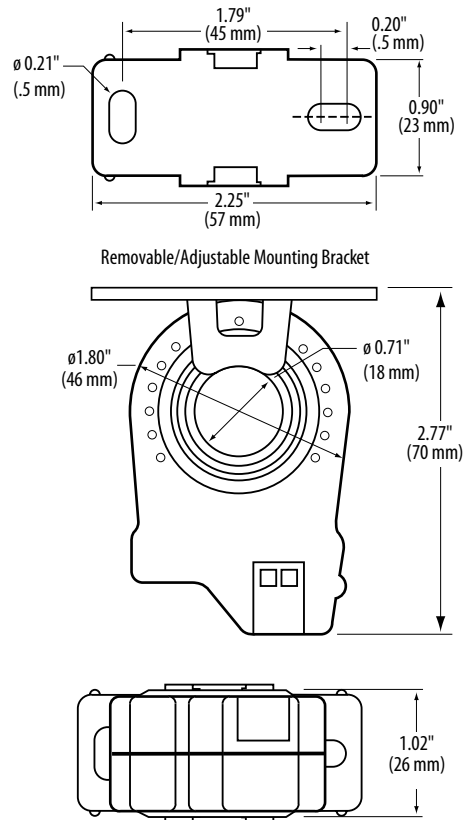

SPECIFICATIONS

Amperage Range	0.75 to 50A
Sensor Power	Induced
Output	Digital switch (see ordering table)
Insulation Class	600VAC rms
Frequency Range	50/60 Hz.
Temperature Range	15° to 50°C
Humidity Range	0 - 95% non-condensing
Hysteresis	10% (typical)
Trip Setpoint	Adjustable 0.75 to 50A
Dimensions... (L x W x H)	2.77" (70mm) x 1.79" (45mm) x 1.02" (26mm)
Sensor Hole Size	0.71" (18mm) diameter
Status Contacts (Hx06 Models):	
Supply Voltage	5-30VDC, continuous supply
Off-state Leakage (max.)	24µA@30VDC
On-state Voltage Drop	1.7VDC (max.)@0.1A

Do not use the LED status indicators as evidence of applied voltage.